



Operation Manual

SSL TELEMETRY SIGNAL INDICATOR

Thank you for your purchasing SANWA 2.4 GHz Receiver "RX-492i". This product manual explains correct uses, safe uses, and product notifications. Please read the manual and follow steps and cautions before using. If you read the manual, please keep it whenever you need to read.

PRECAUTIONS AND WARNINGS

- RX-492i (2.4 GHz spread spectrum transmission system receiver) is for compatible FH5/FH5U transmitters. Other AM/FM/2.4 GHz transmitter cannot use.
- RX-492i designs for 1/10 scale Electric RC model cars or below. Please do not use RX-492i for Nitro Car or bigger than 1/10 scale.
- To combine with devices compatible with SSL can be changed setting by transmitter CODE AUX function.
- Analog Servos is not compatible with SXR, SUR, SSR, SHR mode. Must use analog servos by NOR mode. If using analog servos by SXR, SUR, SSR, SHR mode, the analog servos will be broken. (Analog Servos: Hyper ERG series, RS-995, SX-165T, SPEC series, SRM series)
- BL-RACER, BL-FORCE, BL-SPORT, F3300, F3000, F2200, SBL-01/02/03CR cannot work by SXR, SUR, SSR, and SHR mode. Must use ESC by NOR mode.
- 2.4 GHz frequency band is not only for Radio Control. This frequency band is same as ISM (industrial, scientific, and medical device) uses. There are some possible of interfering by the other devices as Microwave, wireless Lan, digital cordless phone, audio device, gaming device, and VICS. Also amateur radio uses same frequency band. Please take care of interfering from another devices. In case of interfering to the radio station, please stop using and avoiding the interfere.
- Please check safe use and limit to use devices are possible to be interfered in RC circuit. Also, please follow instruction by facility manager.
- In case of running behind the building and steel tower, transmission would be decline or out of control. Please always operate in visible situation.
- Radio Law depends on each country. Imported transmitter or receiver from another countries might be illegal.

2.4GHz NAME OF PARTS, LED CONDITION INDICATOR, AND ANTENNA CONDITION

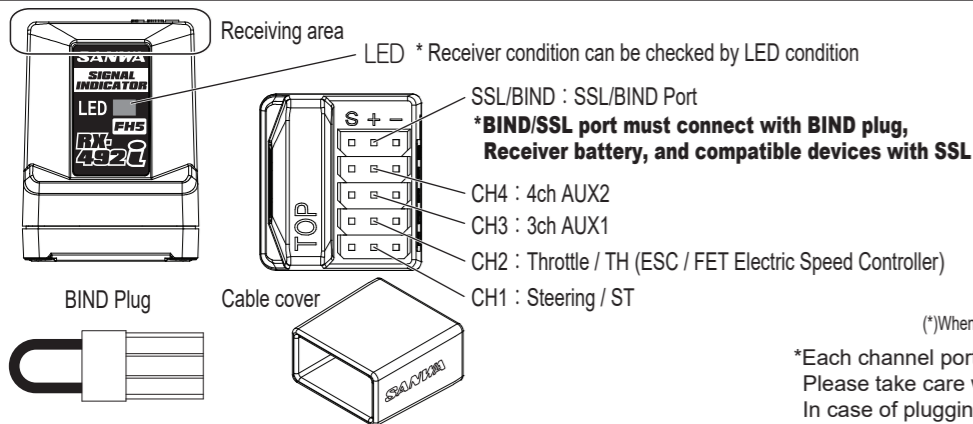

LED condition indicator	
Receiving Transmitter Signal	Blue (*)
No connection	None
Binding Operation	Blue Flash Slow Blue Flash Fast
Battery Fail Safe Mode	Flushing Blue and Red
No connection after Battery Fail Safe operated	RED

(*)When binding with second transmitter, blue light will be flushed for 2 seconds.

*Each channel port is developed by SANWA connector. Please take care when using another manufacture connector. In case of plugging in another connector forcefully, it will be caused case broken or Poor connection.

*Please refer how to place receiver in another page.

2.4GHz SSL SYSTEM

- To combine with devices compatible with SSL can be changed setting by transmitter CODE AUX function.
- In case of using CODE AUX, please change AUX TYPE is [NOR] to [CODE5 or CODE10] in System. To choose CODE5 or CODE10 depends on device which is compatible with CODE5 or CODE10.
- *When using both ESC/ Speed Controller and Servo for SSL, please use Short Y-Harness (optional) to connect to SSL port.
- About CODE AUX, please refer SSL system explanation on our HP. (www.sanwa-denshi.com)

2.4GHz INDICATOR FUNCTION

- RX-492i has indicator function. Indicator function can be used for checking receiver placement and malfunction. The indicator function can be set with compatible transmitter. The transmitter can check receiver signal condition from receiver. About setting of the indicator function, please refer the compatible transmitter operation manual. Also, please check our website (www.sanwa-denshi.com) for checking transmitter is compatible with indicator function or incompatible.

2.4GHz How to Bind with Transmitter

- About BIND : each 2.4GHz transmitter has ID Number. The bind is tied ID Number with receiver. If a receiver bind with a transmitter, the receiver will be worked by the transmitter.
- 1. Please set [RF mode] is [FH5/FH5U] in Transmitter System (Compatible with FH5/FH5U)
- 2. Turn on the transmitter, and set for other devices as response mode. Then, enter [BIND] to be bind mode.
- 3. Connect BIND plug in RX-492i BIND/SSL port. Then, turn on receiver.
- *When you bind transmitter with the receiver, please connect battery in empty port. (In case of EP car, speed controller connect in CH2 port)
- 4. After RX-492i LED will be changed fast flashing blue from slow flashing blue, please take off BIND plug and restart RX-492i (Turn off receiver, then turn on). In case of binding with second transmitter, the blue light will be blinking for each 0.2 seconds.
- 5. Please finish BIND mode on transmitter to use enter/back operation by touch pad. In case of binding with transmitter, LED on the receiver turn on blue. Please operate device as servo to check BIND is completed.
- * In case of turning off LED in the process or did not complete BIND setting, please reset binding form 2. in bind process.

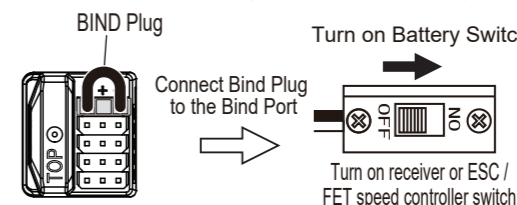
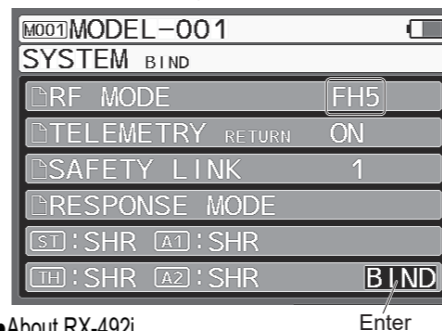

*Did not connect anything above picture but please connect device as servos or ESC / FET speed controller (except motor) when you bind.

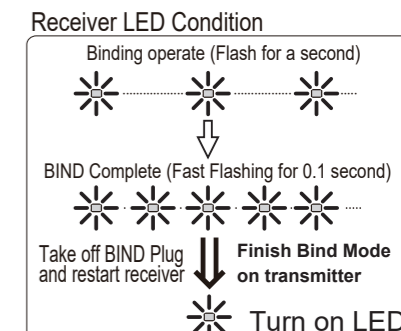

- About RX-492i
- RX-492i can store 2 transmitter ID Number. It is able to combine using individual transmitter which is different setting in endurance race. If you bind with 2 different transmitter, the receiver store the different transmitter and can operate by transmitters without re-bind.
- *CANNOT operate by the 2 different transmitter at the same time. 2 ID store system is only compatible transmitter. (Please refer SANWA HP)
- Throttle neutral position or operation quantities might be different each transmitter. Please adjust each transmitter setting to fit chassis linkage.
- MUST set fail-safe setting on each transmitter.
- Please set same RF mode, response mode, and safety link number as 1st transmitter when you bind 2nd transmitter. If it was different mode, cannot bind with 2 transmitters.
- *If 2nd transmitter was different RF mode, response mode, and safety link number from 1st transmitter, 1st transmitter ID No. is deleted and only write 2nd transmitter.
- *If you bound 3rd transmitter, 1st transmitter ID No. will be deleted.

WARNING

- Default is not bind with transmitter. Please bind with transmitter before using.
- MUST use the receiver with bound transmitter.

PRECAUTION FOR SAFE USE

- Please mount the antenna area of receiver as high as possible in your model.
- Please place receiver apart from motor, metal parts, carbon parts, and ESC / FET Speed Controller (include leads).
- Please place "TOP" indication on receiver head upward.
- Please check surely connection devices as servos and switch with the receiver. In case of losing connection during running, it is possible to be out of control.
- The receiver is weak in extreme vibration, shock, and water. Please take care of vibration, shock, and water.
- Please mount the receiver apart from carbon and metal chassis. Also, please avoid to mount on center of chassis.
- Metal to metal contact in your model will generate to noise. It will interfere the receiver ability and is possible to be out of control.
- Please take noise killer condenser to brushless motor for RC car. If not taking noise killer condenser to brushless motor for RC car, noise will be generated. It is possible to be out of control.
- Please use transmitter, receiver, servo, ESC / FET speed controller made by SANWA.
- *In case of combination of using with devices except SANWA products, we could not take responsibility for any failures.

2.4GHz WARRANTY AND SERVICE INFORMATION

Your RX-492i is warranted against manufacture defects in materials and workmanship. This warranty does not cover suitability for specific application, components worn by use or improper voltage, tampering, modification, misuse, abuse, improper wiring, reverse polarity, moisture damage or acts of Gods. For warranty and service information, please contact the SANWA distributors in your region. For a list of distributors in your region, please visit www.sanwa-denshi.com/rc/distributors.html.



SANWA Electronic Instrument CO., LTD
1-2-50 Yoshita-Honmachi
Higashi Osaka, 578-0982 JAPAN
Telephone : 81-72-962-1277
FACSIMILE: 81-72-964-2831

Note: This equipment has been tested and found to comply with the limits for a Class B digital device pursuant to part 15 of the FCC Rules. These limits are designed to provide reasonable protection against harmful interference in a residential installation. This equipment generates, uses and can radiate radio frequency energy and, if not installed and used in accordance with the instructions, may cause harmful interference to radio communications. However, there is no guarantee that interference will not occur in a particular installation. If this equipment does cause harmful interference to radio or television reception, which can be determined by turning the equipment off and on, the user is encouraged to try to correct the interference by one or more of the following measures: (1) Reorient or relocate the receiving antenna, (2) Increase the separation between the equipment and receiver, (3) Connect the equipment into an outlet on a circuit different from that to which the receiver is connected or (4) Consult the dealer or an experienced radio/TV technician for help.

Changes or modifications not expressly approved by the party responsible for compliance could void the user's authority to operate the equipment.



! HOW TO MOUNT TO 1/10 Scale EP CAR or below scales

When mounting on the car chassis, please place receiver vertically as the below picture. Any other methods might be affect to receiver performance.

- Receiver Placing
Mounting receiver on the chassis and place "TOP" indication upward.

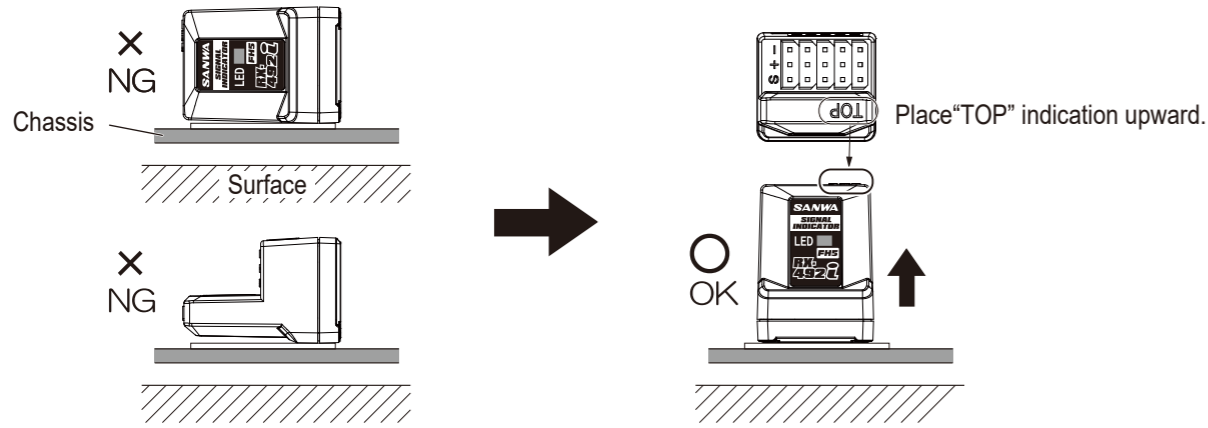

- Receiver Placing Direction
Placing RX-492i label outward.

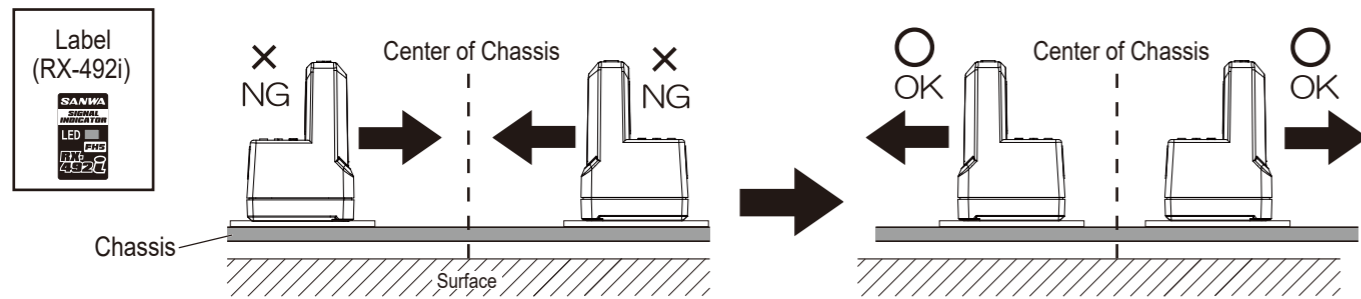

! HOW TO WIRE CABLES WITH RECEIVER

When wiring cables of Servo, Electric Speed Controller, Motor, or Battery, please do not cover on receiver top. It might be affect to receiver performance.

- Please refer below picture how to wire the cables.

— Motor, Battery cables
— Servo, Electric Speed Controller Cables

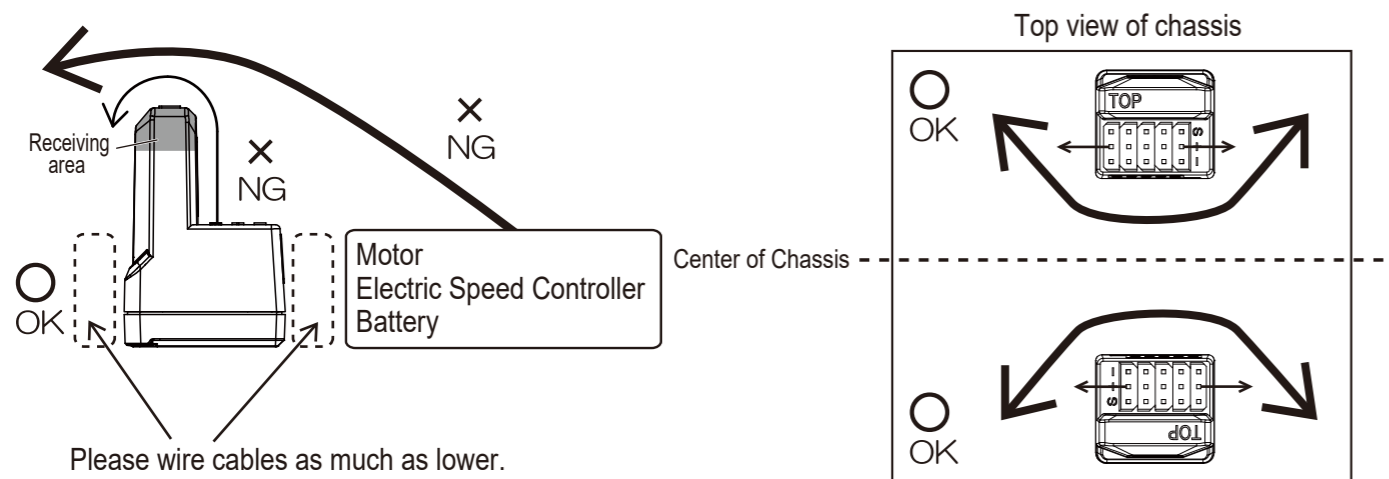

! HOW TO MOUNT TO 1/10 Scale EP CAR or below scales (Another Case)

Mounting RX-492 as below picture in case receiver cannot place "TOP" indicator upward due to body height.

- Receiver Placing
In case of receiver top is over height, please place label upward as the below picture.

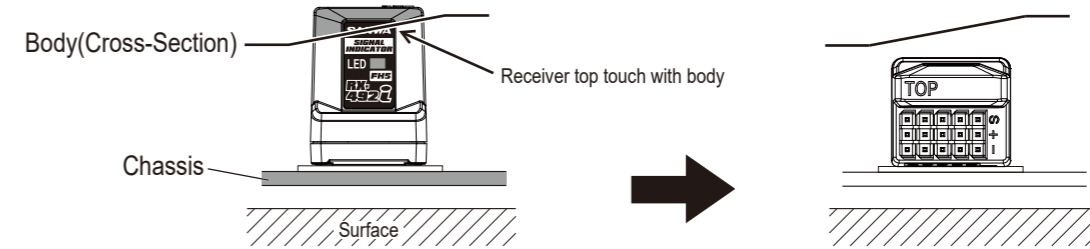

- Receiver Placing Direction
Placing "TOP" indication outward.

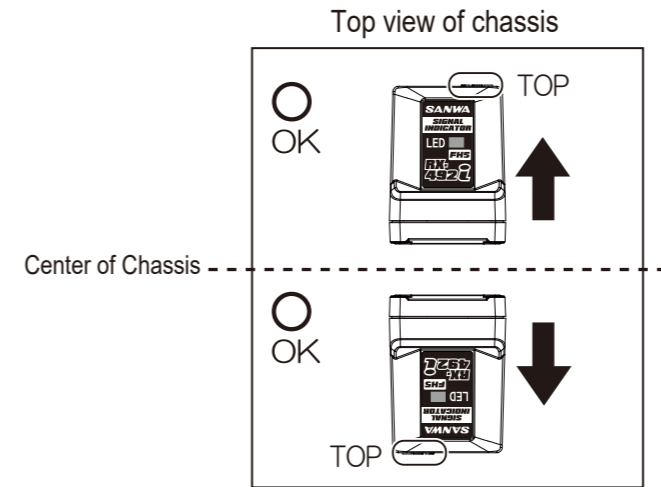

! HOW TO USE CABLE COVER

If feeling declined radio wave or no signal even if placed correctly, please place receiver on cable cover. Receiver sensibility would be greater by higher position.

- Receiver Placing
Placing RX-492i label outward.

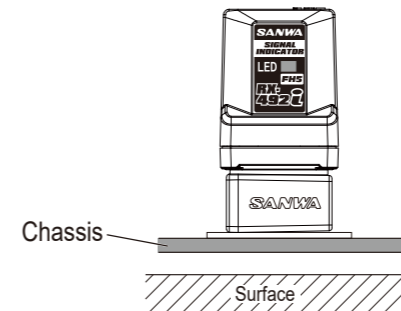

- Wired cables go through into cable cover. It would be easy to install cable cover with receiver as the below picture.

